

ECOLOGY AND DISTRIBUTION OF SILVER BEECH (*NOTHOFAGUS MENZIESII*) IN THE PARINGA DISTRICT, SOUTH WESTLAND, NEW ZEALAND

P. WARDLE

Botany Division, DSIR, Private Bag, Christchurch

SUMMARY: The Paringa district is almost completely forested below timberline, with conifer /hardwood forests pre-ailing in the northeast, and silver beech widely dominant in the southwest, especially at the higher altitudes. In a transitional zone, silver beech grows as scattered stands, isolated by distances up to 6 km.

During heavy glaciation of the mountainous part of the district, silver beech may have survived near the present coast and beyond it on land exposed by a lowered sea level. Post-glacial spread from such refugia to the most inland valley heads would require a spreading rate averaging at least 700 m/century, and it is suggested that this was achieved by dispersal of seed on to freshly exposed mineral soils, where beech seedlings apparently can grow independently of mycorrhizal infection. From the nuclei thereby established there was, and still is, gradual invasion of surrounding vegetation. The post-glacial pollen record and the present distribution of silver beech both indicate a pattern of northeasterly spread.

INTRODUCTION

New Zealand forest is usually seen as comprising two formations; on the one hand the beech forests, and on the other, the wide spectrum of communities for which the collective name conifer / hardwood forest will be used in this paper. Beech forests consist of nearly pure stands of *Nothofagus* spp., and are typically developed in the colder, drier, or less fertile parts of New Zealand. Conifer/hardwood forests usually contain two main tree strata; a tall, often very open one of podocarps, or locally *Agathis* or *Libocedrus*, and a lower one of the broadleaved hardwoods. It is best developed on warm lowlands, and the floristic composition varies widely among communities to the extent that different stands may have few or no genera in common; hence the difficulty in arriving at a fully acceptable collective name for the formation.

Beech and conifer/hardwood forests do not always exist in a predictable spatial relationship, for there are wide areas which might be expected to support beech on grounds of habitat, but which instead support either conifer/hardwood forests in shorter, floristically poorer versions than prevail on warm lowlands, or "subalpine scrub" dominated by epacrids, composites and small conifers. There are gradations between the two formations, especially where high-altitude beech forests merge downslope into conifer/hardwood stands, and on very poor soils where stunted heath-forest can contain a mixture of beeches, conifers, broadleaved hardwoods and *Leptospermum scoparium*. On the

other hand, beech and conifer/hardwood communities are often separated by strikingly sharp boundaries that do not always coincide with evident environmental boundaries.

These relationships have been a major concern of ecologists in New Zealand. In Westland, interest has been in the transitions between the central part of the province, where conifer / hardwood forests extend from the coast up to the subalpine scrub belt on the flanks of the Southern Alps, and the northern and southern parts where mixed forests of podocarps, beeches and other hardwoods prevail at low altitudes, and pass upwards into pure beech forests that extend to the alpine timberline. This paper reports on an exploratory study of the transition in South Westland, with emphasis on silver beech. Evidence is drawn from distribution, community composition, stand structure, growth rates and palynology.

PHYSICAL GEOGRAPHY

The area of interest lies between the Karangarua and Waita Rivers (Fig. 1). It consists of two major topographic units, divided by the Alpine Fault (Mutch and McKellar, 1964; Gair, 1967). In the southeast, there are high schist mountains, many carrying permanent ice and snow, and deep, glacially carved valleys. Between the Alpine Fault and the sea, a hilly area centred on Lake Paringa is flanked to the northeast and southwest by plains filled by post-glacial river and lagoon sediments. The hill country can be further divided into first, the Alpine

Fault zone which is occupied by a glaciated trough northeast of the Moeraki River and a mass of slump material in the southwest; second, inland hills rising to nearly 1000 m of mainly Palaeozoic rocks and, finally, coastal hills of Tertiary rocks that include marine terraces uplifted as high as 450 m.

Ice-age glaciers have extended from the mountains to the present coast and beyond, and receded to leave the depressions occupied by Lakes Paringa and Moeraki, moraine deposits flanking the major valleys, and the prominent moraine ridge that runs out to Heretaniwha Point.

To extrapolate from stations at Franz Josef Glacier and Haast (New Zealand Meteorological Service, 1973), rainfall near the coast is 4000-5000 mm annually and well-distributed, and temperatures are mild and equable. Inland valley floors, especially that of the Landsborough River, evidently experience far more frequent and severe frosts. Yearly sunshine hours are unlikely to exceed 1800, fog, low cloud and rain being especially prevalent along the seaward flank of the high mountains. The climatic gradients run normal to the coast; it is hard to discern any gradients parallel to the coast

that correspond to the marked northeast-southwest differences in vegetation.

VEGETATION AND SILVER BEECH STAND TYPES

Through most of the northern portion of the district, and more locally further south, the vegetation resembles that found in and near Westland National Park (Wardle, 1977), with dense podocarp forest and extensive mires on the flat lowlands, and a sequence from conifer / hardwood forest through subalpine scrub to alpine grassland on the slopes. In the rest of the district, silver beech (*Nothofagus menziesii*) imparts a distinctive appearance and structure to the vegetation. Mountain beech (*Nothofagus solandri* var. *cliffortioides*) also grows in scattered localities centred on Bald Hill.

It is useful to divide communities containing silver beech into *extensive* stands in which the species is well-distributed over all suitable habitats; and *sporadic* stands, which occupy small, discontinuous areas, leaving intervening, apparently suitable terrain without beech. Extensive beech

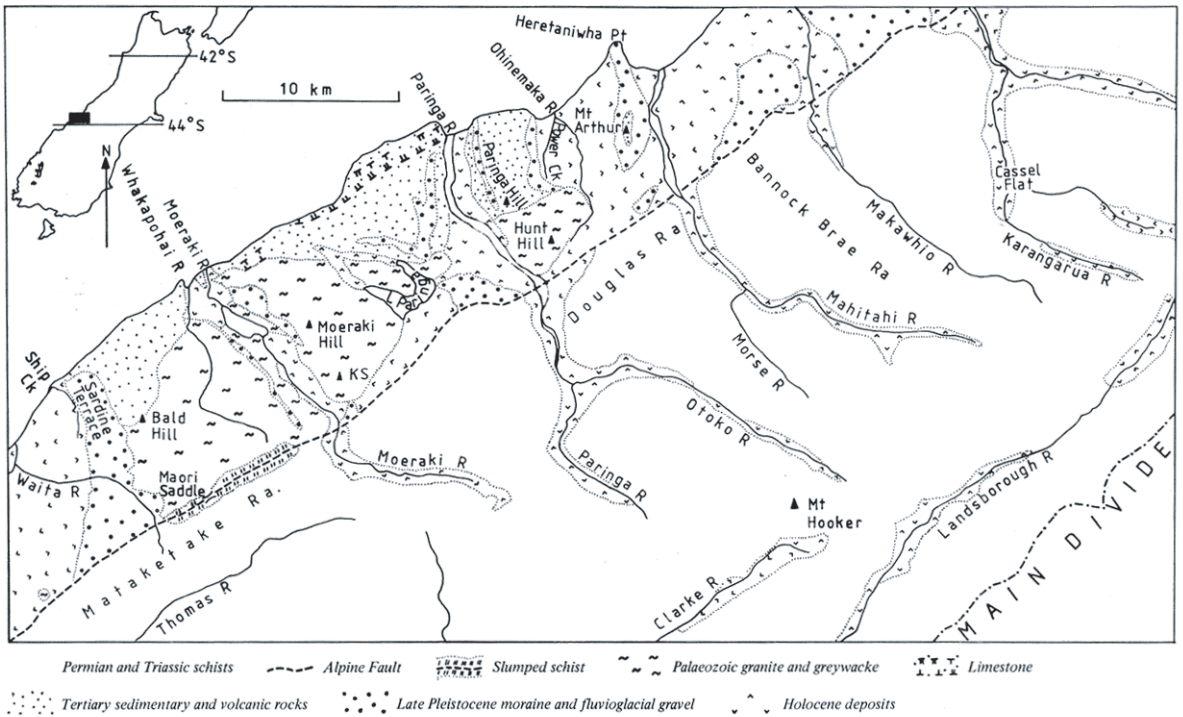

FIGURE 1. Geology of Paringa district (based on Mutch and McKellar, 1964; Gair, 1967).

forests include areas where silver beech forms pure or nearly pure stands; for brevity, these are referred to as *beech-dominant*. They mainly occupy slopes between 500 m and the timberline, but there are also pure beech stands on valley floors, especially in inland valleys. Communities correspond with those described for South Westland by J. Wardle *et al.* (1973).

In extensive *beech-codominant* stands, silver beech shares dominance with trees of the conifer / hardwood forests. Their main occurrence is on mountain slopes and higher hills where the pure, high-altitude beech forests grade downwards into mid-slope stands in which both beech and kamahi (*Weinmannia racemosa*) are important, and there is an overstorey of podocarps, especially rimu (*Dacrydium cupressinum*). Below about 300 m these grade in turn into conifer / hardwood stands (especially the rimu / kamahi / *Blechnum* communities of Wardle, 1977) with little or no beech. However, under the more severe inland climates of the Landsborough and Clarke valleys, nearly pure silver beech forests extend from valley floor to timberline,

and the conifer / hardwood element is represented by little more than sub canopy trees of kamahi and patches of *Blechnum discolor* on the mid-slopes.

Another set of beech-codominant stands are more or less extensive on coastal hills, where infertile soils allow beech to compete with other forest elements. Here, beech can descend to sea level in a range of communities that, in its absence, would approximate to stunted heath-forest on coal-measure quartzites, dense rimu stands on ancient beach terraces, and the variant of rimu / kamahi / *Blechnum* forest that has *Gleichenia cunninghamii* and *Phyllocladus alpinus* conspicuous in the undergrowth.

Many of the sporadic beech stands grow in more or less riparian situations, either on river banks and recent terraces, or on low-altitude slips. These are derived from identifiable seed sources that usually lie upstream, and they can develop into dense stands that remain sharply differentiated from adjacent forest types. Other sporadic stands grow well away from streams, usually on high spurs, ridges and hill crests.

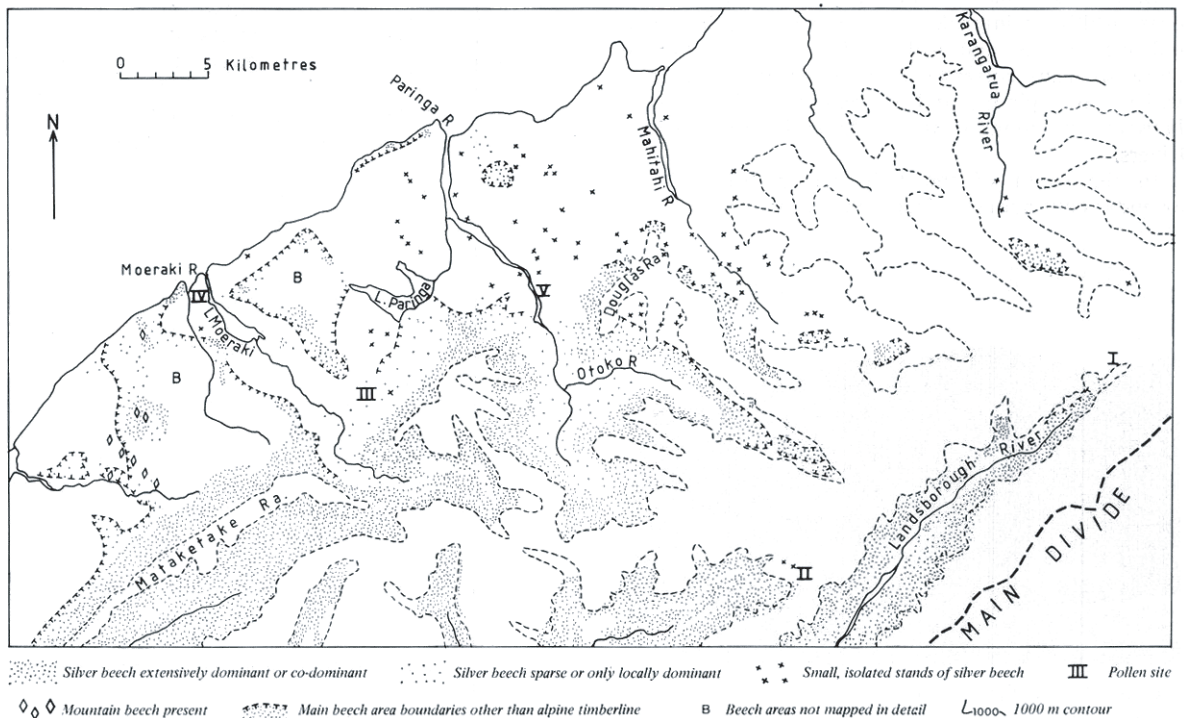

FIGURE 2. Distribution of silver and mountain beech in the Paringa district.

DISTRIBUTION PATTERNS OF SILVER BEECH (FIG. 2)

Extensive forests of silver beech in the mountains extend *en masse* from the south to the head of the Landsborough valley and across the Paringa valley to the southern slopes of the Douglas Range. There are also isolated blocks in the Morse tributary and head of the Mahitahi valley and part of the southern slope of the Karangarua valley. The head and north side of the Otoko valley, the northern slopes of the Douglas Range, and the northern slopes of the Mahitahi valley support sporadic stands. An isolated stand grows on a seaward spur of the Bannock Brae Range, and there is another in the head of the Karangarua valley, while riparian trees extend down the Karangarua River to Cassel Flat. There is, therefore, a broad transition from the continuous beech forests in the south to the beech-free forests of central Westland. Nearly all of these sporadic stands are situated within the high-altitude forests dominated by rata (*Metrosideros umbellata*) and kamahi (*Weinmania racemosa*) or the subalpine scrub above. Even in extensive beech forest areas, the timberline can be locally depressed, with sporadic clumps of beech in the scrub beyond it.

Beech-codominant stands extend all along the coastal hills on infertile soils, including Paringa Hill (686 m) (Fig. 3) and isolated Mt Arthur; although there are gaps corresponding to recent sedimentary valleys and plains, and to outcrops of limestone between the mouths of the Moeraki and Paringa Rivers.

In the south of the hilly region beech forest extends continuously from the coast, across the

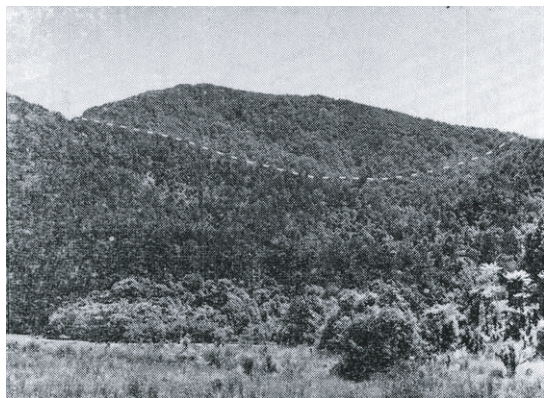

FIGURE 3. On Paringa Hill, a cap of silver beech forest contrasts with the conifer/hardwood forest on the nearer slopes facing Power Creek.

Palaeozoic ridges and fault breccia of the Maori Saddle (640 m), to link with the mountain forests of the Mataketake Range. Beech-dominant forest also caps Moeraki Hill (843 m) and Trig KS (975 m) north of the Moeraki River, but the hills further northeast, including Hunt Hill (792 m), support only sporadic clumps on ridge crests while in the adjacent Alpine Fault trough there is a mosaic of silver beech and conifer/hardwood communities, with the beech tending to prevail in frosty hollows and on recent fans.

The wide alluvial valleys of the Paringa and Moeraki Rivers have riparian stands scattered almost to their mouths, as do smaller streams that have silver beech in their headwaters. Beech is also widely, but not uniformly, distributed over the plain of the Waita River in the southwest but on the northeastern plains there are only a few riparian patches along the Ohinemaka River and Power Creek, an isolated clump within rimu forest on an ancient dune near Heretaniwha Point, and another growing within rimu-kahikatea forest north of the Mahitahi River, 2 km east of Mt Arthur.

Figure 2 shows the distribution on a small scale. It is based on a field survey using aerial photographs taken in 1965, and the information has been checked against the unpublished forest type maps and plot records of the National Forest Survey conducted by the New Zealand Forest Service between 1946 and 1955. A distribution map, drawn at 1:63,360 indicating sources and reliability of information, is available from the author on request.

ESTABLISHMENT SITES OF SEEDLINGS

The kinds of sites that can be exploited by seedlings have a bearing on the establishment of new stands of silver beech, and on the regeneration and marginal spread of existing stands. Notes were made on seedling distribution, especially in stands selected for measuring tree size classes.

Where there is a nearby seed source, silver beech seedlings vigorously colonise recently exposed mineral surfaces, including alluvium, moraine, landslide debris and road embankments. Within forest, seedlings can become established on mineral soil, humus, or mossy bases of living beech trees. The distribution among micro-sites varies according to forest type.

In beech-dominant stands near timberline (i.e. above c. 900 m) seedlings grow mainly on humus- or moss-covered ground or on rocks, whereas in two stands at about 650 m, noticeably more seedlings were sited on logs and tree bases than on the ground. This is probably related to the *Blechnum discolor* understorey which ascends to about this

level. At lower altitudes on the seaward slopes of the main ranges, the stands become "beech-codominant". Their understorey is generally dense, and silver beech seedlings are sparse and localised; they were recorded mainly on the ground around the bases of mature beech trees where the understorey is suppressed, and some were seen on raised sites such as logs and stumps. However, on the sharper, drier spurs at mid-altitudes beech can be more abundant in both the canopy and as seedlings. It also shows a marked ability to establish where patches of mineral soil have been exposed by wind throw or small slumps.

In the low-altitude, beech-codominant stands near the coast, seedlings are abundant, and the great majority are sited on bare or mossy ground. This probably reflects two circumstances. On one hand, as soils are less fertile and rainfall and humidity are lower than further inland, understoreys are less developed and compete less with beech seedlings on the ground. On the other hand, the raised sites such as logs and stumps are drier here, and not as favourable for beech seedlings.

Sporadic stands tend to show the same patterns of seedling distribution as extensive stands in comparable environments, although low-altitude stands, as already noted, may depend for regeneration on continued disturbance or on elevated micro-sites. The rimu-kahikatea (*Dacrycarpus dacrydioides*) forest on the wet terrace north of the Mahitahi River seems an unlikely habitat for silver beech, but the isolated stand here is maintaining itself through several mode} of regeneration. Similar numbers of seedlings were counted on the ground as compared with logs and stumps (12 cf. 19 seedlings < 1 m tall in the total stand area of 600 m²), and there is a pronounced tendency for saplings and small trees to fall over and give rise to 2-4 new upright stems. Old trees that have gained renewed vigour through producing adventitious roots, and trees of epiphytic origin are also present.

In summary, the dependence on elevated micro-sites such as logs, noted by June and Ogden (1975) for red beech (*Nothofagus fusca*), prevails with silver beech in the Paringa district where there is a well-developed understorey; where the latter is sparse or absent, seedlings are more abundant and mostly ground-based.

The district supports introduced red deer (*Cervus elaphus scoticus*), and numbers were much higher before hunting pressure greatly increased in the 1960s. While silver beech seedlings show signs of intermittent browsing, there is no obvious browse-induced age-gap, and modification of the denser silver beech forests appears to be slight. On

immature soils where silver beech forms an open canopy over fast-growing, palatable species such as *Griselinia littoralis* or *Fuchsia excorticata*, the latter are usually severely browsed (cf. J. Wardle *et al.*, 1973), and locally death of beech trees in damp areas is associated with destruction of the topsoil by trampling and exposure of roots. However, the brunt of the browsing pressure has fallen on the alpine grasslands, which are now in a good state of recovery and on the higher-altitude conifer / hardwood stands, which still have severely modified understoreys.

GROWTH RATES

This part of the investigation is based mainly on single increment cores taken from selected vigorous trees, since the rate of spread to new areas and, to a large extent, the regeneration of established stands is likely to depend more on such trees than on those of "average" or suppressed plants. The growth rings can be assumed to be predominantly annual.

In Table 1, the growth data are based on the average ring width per 5 cm length of core; only the part of each core that represents growth from 10 cm to 60 cm in diameter is used, to avoid the influence of both initial suppression and old age. The data on the left of the table represent trees growing in marginal or pioneer situations, the middle represents trees from within forest, and those on the right represent stunted trees growing in heath-forest (at 400 m) and heath-scrub (at timberline).

Pioneer trees on recent alluvium grow fastest, and trees in heathland slowest. Growth rates on comparable sites tend to decrease with increasing altitude (cf. Ogden, 1978) but even at timberline growth rate is not a limiting factor, for although trees in a closed stand just below timberline (1060 m) have grown slowly, marginal trees are capable of substantial growth.

These growth rates are much higher than those measured by Herbert (1973) in silver beech stands in northern Fiordland, where mean ring widths ranged from 0.9 mm at favourable mid- or low-altitude sites to 0.4 mm near timberline. Herbert's data represent average growth rates, rather than optimal values of the present study. He also used 4 short cores per tree, instead of single long cores; to compare the two methods, four cores were extracted from each of 14 trees in the Paringa district. Table 2 shows, for each tree, that mean values for ring width taken from the most rapidly grown radius are higher (but on average by only 18%) than those calculated from 4 radii,

TABLE 1. *Ring widths (mm) in single increment cores from selected silver beech trees (see text).*

Altitude (m)	Trees Cored	Margins etc.			In forest			In heathland			
		Max.	Mean	S.D.	Max.	Mean	S.D.	Max.	Mean	S.D.	
10	3				2.5	1.3	0.7				Isolated clump in kahikatea-rimu forest
15	3	5.0	2.5	1.1							Mature riparian clump
30	3	10.0	5.9	2.9							Young riparian trees
60	3				2.8	2.2	0.4				Extensive codominant on coastal slope
130	6				5.0	2.7	1.5				Extensive codominant on coastal slope
180	8	7.2	3.5	1.7							Stand of riparian origin
400	2							0.9	0.7	0.2	Scattered in low heath-forest
400-650	4				3.6	1.9	1.0				Scattered large trees in montane forest
450	2	3.1	2.4	0.6							Pioneers on fan
450	14	2.9	1.3	0.5							Pioneer to mature stands on moraine
550	5	5.0	3.2	1.6							Marginal and central trees of riparian stand
550	6	5.0	2.4	1.5							Pioneers on fan
750	4	4.2	3.2	0.7							Clump that colonised a slip
850	4	3.8	2.4	0.8							Young trees on steep slope
850	6				3.8	2.8	1.0				Isolated mature stand
850	2	5.0	3.3	0.8							Pioneers on moraine
950	1	2.0	1.2	0.7							Mature stand on moraine
980	4	3.3	2.1	0.7							Mature trees at open timberline
1020	2							1.5	1.1	0.4	Stunted trees in subalpine heath-scrub
1060	5				2.1	0.9	0.6				Subalpine extensive dominant
1150	5	4.5	2.3	0.8							Trees at margin of compact timberline

Max. represents the widest rings (averaged over a 5 cm length of core) in the whole sample.

Mean represents the mean of the 5 cm-averages for the whole sample.

S.D. is the standard deviation.

whereas values obtained from the outer 2.5 cm of core as in Herbert's study averaged 30% lower than those calculated from longer cores. It seems, then, that both the maximum and mean values in Table 1 provide reasonable estimates of the growth rates of vigorous trees.

Growth of beech seedlings and saplings varies widely according to amount of competition and shading (Manson, 1974). Slowest growth was recorded from saplings 2.3 m and 3.4 m tall in heath-forest at 400 m, which had 38 and 57 growth rings respectively, representing a mean ring width of 0.3 mm (cf. Table 1).

Although silver beech seedlings and saplings usually develop an erect habit with a single leading shoot, those in beech-dominant stands

near timberline and in scrub or low vegetation immediately above the timberline tend to grow out horizontally, and these horizontal branches can form adventitious roots. This growth form is related both to winter die-back and spring frosting (especially in seedlings outside the forest), and to weak growth of the higher shoots. Under favourable conditions, however, such seedlings eventually develop vigorous upright, leading shoots, and even above timberline shoot growth up to 27 cm/year was measured.

STAND STRUCTURE

Tree diameters were measured in 21 stands. (Appendix 1). In each, measurements were made over apparently uniform vegetation until a reasonably

TABLE 2. Growth ring widths (mm) measured on 4 cores from each of 14 trees.

Tree No.	Altitude (m)	Diameter (cm)	Max.	Mean (core with widest rings)	All 4 cores		Mean (outer 2.5 cm of 4 cores)	
					Mean	S.D.		
1	5	71	8.1	6.3	5.3	1.2	2.9	} Young riparian trees
2	5	55	7.6	5.8	5.7	0.9	4.8	
3	50	39	1.9	1.2	0.8	0.4	0.8	} Extensive codominant on lower slope of Alpine Fault trough
4	50	66	2.5	1.5	1.3	0.5	0.7	
5	50	46	3.2	1.0	0.9	0.6	1.0	
6	50	93	5.4	3.1	2.0	1.2	1.3	
7	50	68	-	-	-	-	7.1	Stream fan
8	50	55	2.6	1.4	1.2	0.5	1.0	Swampy forest
9	1050	15	0.8	0.4	0.4	0.2	0.4	} Extensive dominant close to timberline
10	1050	22	1.3	0.7	0.7	0.2	0.5	
11	1050	27	1.4	1.0	0.8	0.3	0.7	
12	1050	37	2.2	1.3	0.9	0.5	0.5	
13	1050	65	1.4	0.7	0.6	0.3	0.4	
14	1050	95	2.1	1.3	1.0	0.4	0.2	

Max. represents the average ring width in the longest 10-ring section of any of the 4 cores.

Mean is that of the 10-ring averages.

With the exception of Tree 6 and the values for the outer 2.5 cm of core in Trees 1, 4, 6, 7, 13 and 14, all data are based on the parts of the core that represent growth from 10-60 cm diameter. In Tree 7 near-cessation of growth (probably during an episode of flooding) makes some of the inner rings indistinguishable.

representative sample had been obtained, and the area was then determined. The results (six of which are shown in Figure 4 as size-class histograms) suggest widely different age-class structures among stands although, as the preceding section has made clear, diameters show only broad correlations with age.

Most of the extensive stands sampled tend to contain a continuous range of size-classes, with numbers progressively diminishing towards the larger classes (Fig. 4 A-C). In principle, this structure is consistent with a "steady-state" population in which there is annual recruitment of seedlings and gradual depletion as these plants pass through successive larger size-classes. However, within each size-class, a wide range of ages must be expected, and this kind of size-class distribution doubtless conceals large variations in rates of regeneration and death through the life of the stands. Catastrophe leading to even-aged stands also plays a local role, i.e. windthrow, avalanche, landslide and flood. In the mid-slope beech-codominant stands (Fig. 4 D), silver beech tends to be represented by scattered, large, old trees, and any young plants are largely confined to the bases of old beeches or beech stumps. These old trees probably represent opportunist establishment into an environment where beech

seedlings are usually unable to compete with dense understoreys.

Sporadic riparian stands at low altitudes might be expected to become gradually supplanted by species of the adjacent conifer / hardwood forest, but in fact they seem remarkably persistent (Fig. 4 E). Often, continued disturbance provides opportunities for continued regeneration, or again, young beeches may become established on the bases of moribund and dead veterans.

A few of the sporadic stands on hillsides and crests (Fig. 4 F) show a distinctly concentric structure, with a core of old trees surrounded by younger ones. In others, part of the margin is more or less static, while the stand is clearly advancing at other points where it is facing less competition from adjacent vegetation. Generally, sporadic stands are more than holding their own, and in most there is a strong bias towards the younger size-classes. Slips from the sides of spurs, heads of eroding gullies, and tops of bluffs are commonly the points of initiation for sporadic stands. That some nuclei became established in the face of full competition from the surrounding vegetation is a possibility that has been neither confirmed nor excluded during this study.

Occasionally, in mid-altitude kamahi-dominated

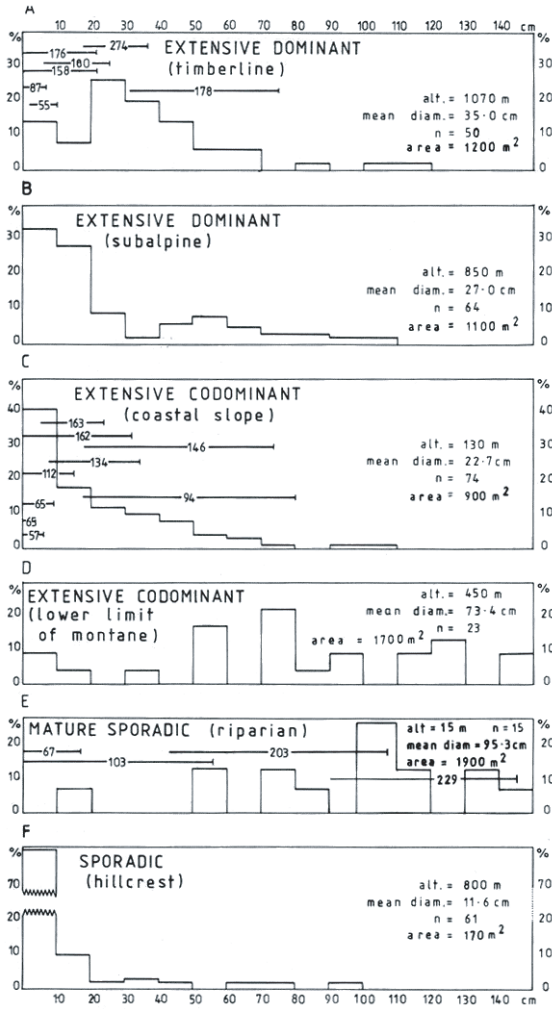

FIGURE 4. Diameter distribution of stems > 1 m tall in 6 representative silver beech stands. The histograms show the percentage of the sample in each 10 cm diameter b.h. class. At three of these stands, single cores were extracted from some trees, and are represented as horizontal bars. The length of the bar corresponds to 2X the length of the core on the scale of the horizontal axis; the digit is the number of growth rings; and the position of the right end of the bar corresponds to the diameter of the cored tree.

forest, isolated veteran beech trees were seen which were accompanied by no younger trees, and very few seedlings. Probably, competition from both the parent beech trees and the surrounding forest

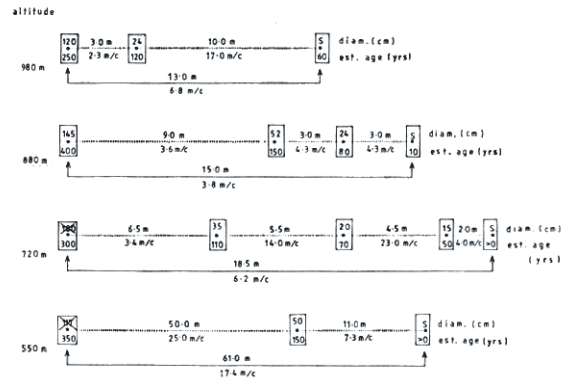

FIGURE 5. Establishment distances of silver beech. The 2 lower sites represent spread into conifer / hardwood forest, the 880 m site spread into dense subalpine scrub with *Libocedrus bidwillii* trees, and the highest site spread into a mosaic of tall scrub and *Chionochloa* grassland at timberline.

In each box the upper number represents the diameter of a tree (a cross indicates a dead tree or stump, "s" a seedling < 1 m tall), and the lower number an estimate of age. Above the dotted line is the distance separating plants, and below, an estimate of its rate of spread in m/century.

prevent these seedlings from growing up, but that they can be released upon the death of their parent is shown by an instance where the gap left by a fallen, nearly rotted, isolated veteran is now occupied by 12 saplings ranging up to 4 m tall.

RATE OF SPREAD OF BEECH

The pattern of beech distribution obviously reflects a general northward spread, as there is no evidence at all that the sporadic stands result from contraction of range. Figure 2 shows that silver beech seed has been dispersed over 6 km, and quite commonly over several hundred metres. The greatest distances directly observed were 140 m for a young tree established in dense montane scrub, and 110 m for seedlings at the centre of an avalanche track.

Marginal spread of sporadic stands seems to depend on marginal trees growing large enough to suppress competing species. At 16 sites (Appendix 2; four are shown in more detail in Fig. 5) the distances from mature trees to young trees, saplings and seedlings, were measured. Diameters were also measured, but no cores were extracted. However, tree ages have been estimated assuming radial growth rates of 1-2 mm per year (in line with the rates shown in Tables 1 and 2); and these in turn

have led to estimates of the rate of spread. Very approximately, the latter average 6 m per century; and no reasonable estimate could alter the inference that marginal spreading rates of silver beech into adjoining forest are of a far lower order than can be achieved by dispersal of seed.

Spread into heathland with a discontinuous cover of woody plants is evidently more rapid than into closed forest or subalpine scrub. This is well illustrated in the Karangarua valley, where silver beech has fully infiltrated some 400 ha of heathland. The opposite side of the valley supports montane forest, with beech restricted to small clumps, most of which established on slips and gullies (Wardle, 1980).

Baylis (1980) discusses the spread of silver beech in relation to its need to form ectotrophic mycorrhizae. In most natural soils, uptake of enough phosphorus for growth is absolutely dependent on symbiosis with suitable fungi; Baylis suggests that an important reason for the generally slow marginal spread is that seedlings are only likely to encounter these fungi within the rooting zone of established beech trees. The more rapid spread of silver beech through heathland possibly is related to the presence of *Leptospermum scoparium*, as this belongs to the only other important native genus that can be ectomycorrhizal (McNabb, 1965). On new soils developing from weathering rock or fresh alluvium, however, phosphorus levels should be high enough to support non-mycorrhizal beech seedlings. Isolated seedlings from far-dispersed seed should therefore be able to grow on such soils, at least in the absence of competition and until they encounter suitable fungi.

During the present study, it was confirmed that silver beech seedlings and saplings growing within forest, including those in small sporadic stands, are fully mycorrhizal. Those growing on gravel stream fans well beyond the rooting zones of mature trees in the Ohinemaka catchment and near Reef ton in North Westland are more variable. In this habitat, two-month old silver beech seedlings lack evident mycorrhizae (although a *Nothofagus fusca* seedling of this age was heavily infected), and older seedlings and saplings tend to have few of the usual thick, light-coloured mycorrhizae. Small, black mycorrhizae of the type associated with the non-specific symbiont *Coenococcum graniforme* (Mejstrik, 1972) are more abundant, but most of the root systems, especially the periphery, consist of long, slender rootlets with root hairs 0.5 mm long. This suggests that although mycorrhizal infection of isolated seedlings may be more rapid than indicated by Baylis, the nutrition

of such seedlings on recently deposited alluvium does not depend on mycorrhizae.

PALYNOLOGY

Dr N. T. Moar (pers. comm.) has analysed four pollen profiles for this study, and analyses from a

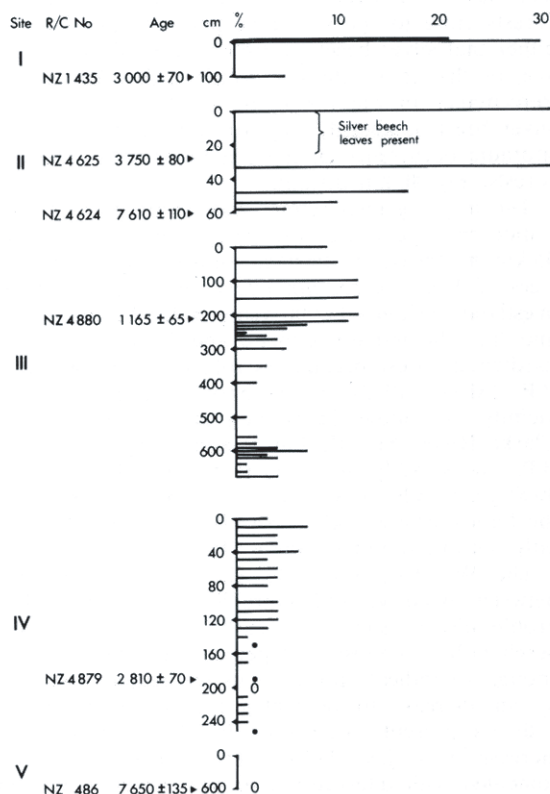

FIGURE 6. Pollen sites, as numbered in Figure 2.

Site	Grid Ref.	Altitude	Locality
I	S88/595276	1100 m	Near head of Landsborough River
II	S88/143399	1040 m	Saddle Greek bog
III	S87/115247	80 m	Windbag bog
IV	S77/017325	3 m	Mouth of Whakapohai River
V	S78/236313	30 m	Paringa Bridge

R / G No.: Radiocarbon No.

Age: Radiocarbon years Before Present, based on a half-life of 5568 years, and not corrected for secular effects.

cm: Depth of sample below surface.

%: Percentage of silver beech pollen to total tree pollen.

. or 0: Trace of or no silver beech pollen respectively.

fifth site were obtained from Suggate (1968). The percentages shown in Figure 6 are for silver beech pollen in relation to the total pollen from woody species. Their significance can be assessed from data on modern pollen rain (Moar, 1970; McKellar, 1973).

Thirty per cent, or even a figure as low as 17 % can mean that silver beech is dominant in extensive forests close to the site. Five per cent can indicate either that silver beech is present sporadically at the site, or that it is extensive within a few kilometres. Percentages in the range 0-3 need not mean that silver beech is absent; they are quite consistent with sporadic occurrence in the region or with extensive forests, say 40 km distant.

The major glacial retreat was taking place 14000 radiocarbon years ago (Suggate, 1968). Sites 65 and 45 km northeast of Paringa respectively show that trees of *Metrosideros umbellata* were present on the Westland lowlands 11 000 years B.P. (Wardle, 1978), and that the modern climate and lowland conifer / hardwood forest became established 9-10 000 years B.P. (Moar, 1973). Silver beech had reached the vicinity of Saddle Creek bog at the head of the Clarke River (Site II, Fig. 2 and 7) by 7600 years B.P., and steadily increased to become dominant by 4000 years B.P. It was significant near the head of the Landsborough valley (Site I) 3000 years ago, but only became dominant there after that time.

The Windbag bog (Site III) is in the ecotone between extensive and sporadic beech stands. The profile clearly shows an early stage, when silver beech pollen is present at percentages that are high enough to indicate presence in the region, followed by an increase to percentages that are consistent with its present abundance in the vicinity. This increase was just before 1165 years B.P. and coincided with interruption of peat accumulation in the mire by 47 cm of silt, suggesting that it was related to disturbance of the catchment. Since then, very wet peat has accumulated rapidly. A single sample from Paringa Bridge (Site V), nearer the northern limit of the beech area, shows no beech pollen at 7650 years B.P.

Site IV, at the mouth of the Whakapohai River, is on a former lagoon where peat began to accumulate about 2810 years B.P. The site is now covered by heath-forest of small dacydiums, and is closest to the beech stands on the coastal hills, although only two silver beech trees were seen in the rimu forest bordering the sampling area. The low, but consistent, percentages of silver beech pollen in the basal part of the profile may result from a sparse local presence, while the rise may reflect an increase of beech in the hinterland.

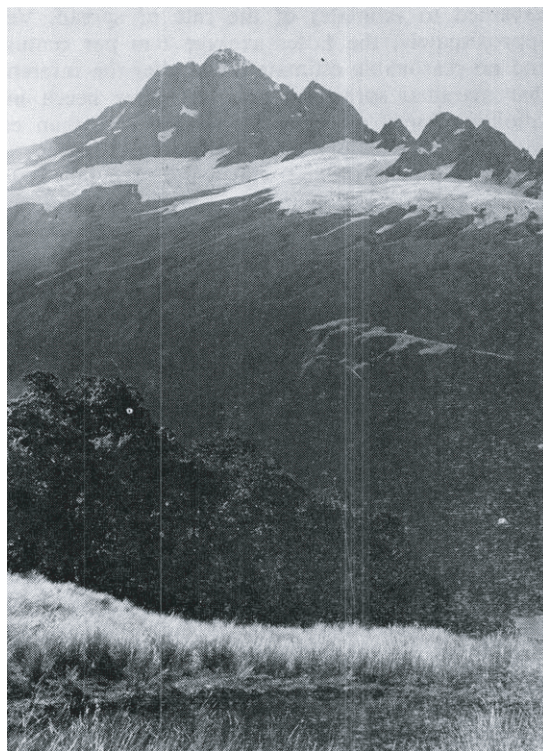

FIGURE 7. Saddle Creek bog (Pollen site II), with a silver beech timberline and Mt Hooker (2652 m) in the background.

However, this rise also coincides with a halving of the percentage of the hitherto-dominant rimu pollen, which suggests that the sampling area could have become more receptive to distant pollen after the low heath-forest locally replaced tall rimu forest.

Overall, the pollen data supports the distribution data in indicating a pattern of northeasterly spread.

HISTORY

The information in this paper leads inevitably to the question of where silver beech survived the rigours of the last, or Otira, glaciation.

Obviously, there were no refugia within the high mountains, as glacial ice filled the inner valleys to altitudes of 1000-1500 m above present sea level, which is about as high as the depressed Otiran permanent snow line (Fig. 8). Where the glaciers emerged from the mountains across the Alpine Fault, their surfaces were at about 450-500 m. Although this left the intervening schist ranges such

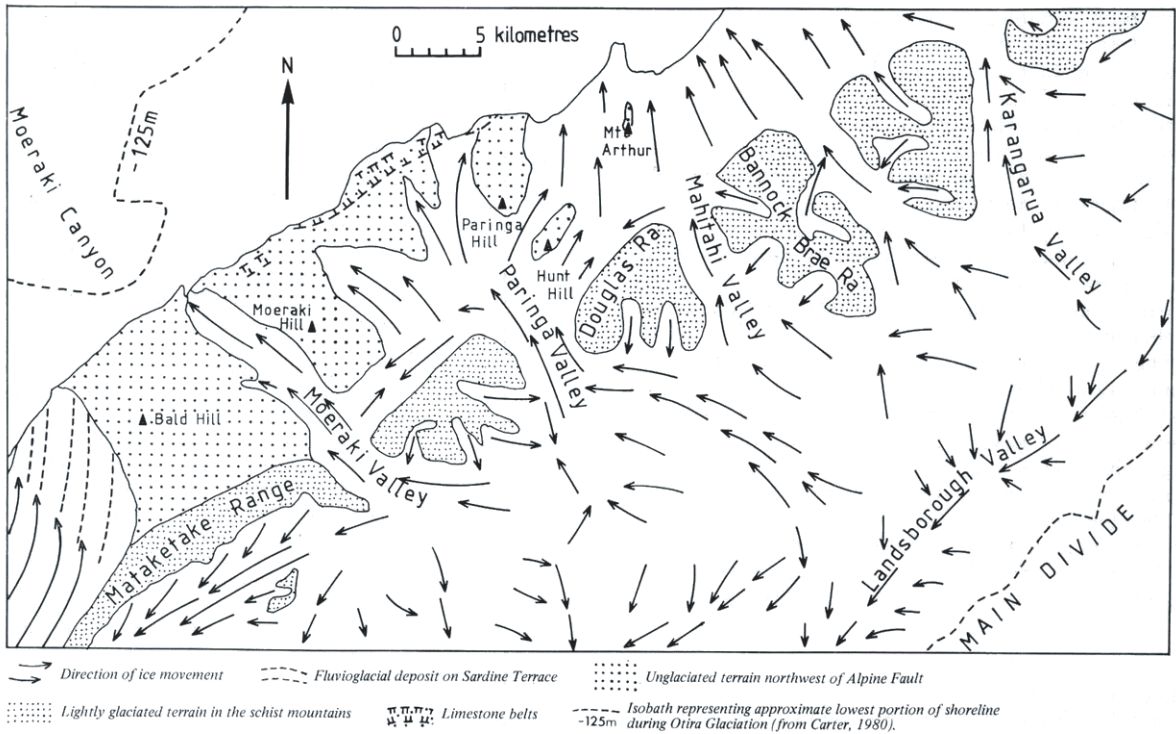

FIGURE 8. Extent of ice during Oтира Glaciation

as the Mataketake and Douglas free of heavy ice cover, their rolling crests are dotted with small cirques down to an altitude of 1050 m.

The unglaciated terrain northwest of the Alpine Fault offers better prospects for forest survival. The presence of silver, mountain, red, and even hard beech (June, 1977) in the Arawata area, 60 km southwest of Paringa, suggests a major refugium there; and in terms of areas not covered by ice, the Paringa-Moeraki district must have provided just as much scope for forest survival. Silver beech grew near Ship Creek during the last interglacial (Nathan and Moar, 1975) so it is feasible that it survived near the present coast, or beyond it on land exposed by the ice-age fall in sea level. From the mouth of the Paringa River northwards, the continental shelf off the west coast of the South Island is mainly smooth and featureless (Norris, 1978), and even allowing for burial by post-glacial sediments, the terrain exposed during the Oтира Glaciation would have been of low relief. In contrast, the exposed shelf to the south was far more indented, with submarine canyons extending as deep inlets to within 2 km of the present coast (Carter, 1980),

and accordingly, there was more likelihood of glacial severity being ameliorated by mild maritime influences.

When the climate became warm again, the species of the conifer / hardwood forest, all possessing seeds that are readily dispersed by birds or wind, and probably readily forming endomycorrhizas with resident soil fungi, spread rapidly and overwhelmed the cold-climate vegetation on the lowlands. Beech could still compete along the coast by growing on infertile Tertiary strata, but only in the south of the district was it able to spread back across the hills to the mountains. Further north it was barred, first by the belt of limestone, and then by the deep trough along the Alpine Fault.

For this post-glacial spread of silver beech to have reached the head of the Landsborough valley from the nearest possible refugium demands a minimum rate of spread of 700 m / century. Among the trees colonising a fan in the Otoko valley, the smallest bearing some seed in 1979 and the smallest seeding heavily had 45 and 65 growth rings respectively. These figures, if typical, indicate that dispersal distances averaging at least 300 m must

have been sustained through the post-glacial period. As silver beech pollen is represented in the basal peat of the three southern pollen sites, it is possible that much of this spread took place during the early Holocene, when landscape instability following glacial retreat would have provided extensive surfaces well suited to beech in its pioneering role. Attainment of dominance or codominance requires coalescence, by the process of slow marginal spread, of the sporadic nuclei established by rapid dispersal. At present, spread is taking place mainly along streams, and on slopes between 500 m and the alpine timberline.

The information provided in this paper supports Holloway's (1954, pp. 384-7) conclusion, based on distribution patterns which were still imperfectly known, that silver beech "is universally the aggressive species" in the forests of south Westland. However, the time span for its spread would seem to be the whole of the post-glacial period, and climatic oscillations of recent centuries, as postulated by Holloway, are unlikely to have greatly influenced the broad features of silver beech distribution.

ACKNOWLEDGEMENTS

Distribution records have been augmented from unpublished National Forest Survey plot sheets, made available by Mr J. L. Nicholls of the Forest Research Institute. I have been assisted in the field by Messrs Andrew Campbell and Robert Wardle, and others whose company made field trips possible. Local residents have helped with information and transport, especially Mr Ron Hoglund of Lake Paringa.

I am especially indebted to Dr Neville Moar of Botany Division, who has carried out pollen analyses, and made preliminary results available for this paper.

REFERENCES

- BAYLIS, G. T. S. 1980. Mycorrhizas and the spread of beech. *New Zealand Journal of Ecology* 3: 151-153.
- CARTER, L. 1980. Jackson Bathymetry, New Zealand Oceanographic Institute chart, coastal series, 1: 200,000.
- GAIR, H. S. 1967. Sheet 20 Mt Cook (1st ed.) *Geological Map of New Zealand 1:250,000*. Department of Scientific and Industrial Research, Wellington.
- HERBERT, J. 1973. Growth of silver beech in northern Fiordland. *New Zealand Journal of Forestry Science* 3: 137-51.
- JUNE, S. R. 1977. A major range extension for hard beech (*Nothofagus truncata*) in the South Island (note). *Mauri Ora* 5: 119-21.
- JUNE, S. R.; OGDEN, J. 1975. Studies on the vegetation of Mt Colenso, New Zealand. 3. The population dynamics of red beech seedlings. *Proceedings of the New Zealand Ecological Society* 22: 61-6.
- McKELLAR, MARY H. 1973. Dispersal of *Nothofagus* pollen in eastern Otago, South Island, New Zealand. *New Zealand Journal of Botany* 11: 305-10.
- McNABB, R. F. R. 1968. The Boletaceae of New Zealand. *New Zealand Journal of Botany* 6: 137-76.
- MANSON, B. R. 1974. The life history of silver beech (*Nothofagus menziesii*). *Proceedings of the New Zealand Ecological Society* 21: 27-31.
- MEJSTRIK, V. 1972. The classification and relative frequency of mycorrhizae in *Nothofagus solandri* var. *clidortioides*. *New Zealand Journal of Botany* 10: 243-53.
- MOAR, N. T. 1970. Recent pollen spectra from three localities in the South Island, New Zealand. *New Zealand Journal of Botany* 8: 210-21.
- MOAR, N. T. 1973. Contributions to the Quaternary history of the New Zealand flora 7. Two Aruanian pollen diagrams from central South Island. *New Zealand Journal of Botany* 11: 291-304.
- MUTCH, A. R.; McKELLAR, I. C. 1964. Sheet 19 Haast (1st ed.) *Geological Map of New Zealand, 1:250,000*. Department of Scientific and Industrial Research, Wellington.
- NATHAN, S.; MOAR, N. T. 1975. Late Quaternary terraces between Ship Creek and the Whakapohai River, South Westland, New Zealand. Appendix: pollen analyses from the Sardine Terraces. *Journal of the Royal Society of New Zealand* 5: 313-27.
- NEW ZEALAND METEOROLOGICAL SERVICE, 1973. *Summaries of Climatological Observations to 1970*. Government Printer, Wellington. 77 pp.
- NORRIS, R. M. 1978. Late Cenozoic Geology of the West Coast shelf between Karamea and the Waiho River, South Island, New Zealand. *New Zealand Oceanographic Institute Memoir* 81. 28 pp.
- OGDEN, J. 1978. On the diameter growth rates of red beech (*Nothofagus fusca*) in different parts of New Zealand. *New Zealand Journal of Ecology* 1: 16-8.
- SUGGATE, R. P. 1968. The Paringa Formation, Westland. *New Zealand Journal of Geology and Geophysics* 11: 345-55.
- WARDLE, J.; HAYWARD, J.; HERBERT, J. 1973. Influence of ungulates on the forests and shrub lands of South Westland. *New Zealand Journal of Forestry Science* 3: 3-36.
- WARDLE, P. 1977. Plant communities of Westland National Park (New Zealand) and neighbouring lowland and coastal areas. *New Zealand Journal of Botany* 15: 323-98.
- WARDLE, P. 1978. Further radiocarbon dates from Westland National Park and the Omoeroa River mouth, New Zealand. *New Zealand Journal of Botany* 16: 147-52.
- WARDLE, P. 1980. Primary succession in Westland National Park and its vicinity, New Zealand. *New Zealand Journal of Botany* 18: In press.

APPENDIX 1
NUMBERS OF SILVER BEECH STEMS > 1 CM TALL IN 10 CM DIAMETER CLASSES

Grid ref. NZMS 1	Altitude m	Area m ²	Diameter b.h. classes										Stand Type						
			-10	-20	-30	-40	-50	-60	-70	-80	-90	-100		-110	-120	-130	-140	-150	-160
*S78/283327	1070	1200	7	4	13	10	7	3	3	-	1	-	1	1					Extensive dominant, timberline
S88/400143	1070	300	35	19	-	1	-	2	2	1	-	1							Extensive dominant, timberline
S88/337158	1000	nm	4	13	12	5	1	3								x			Extensive dominant, influenced by avalanche
*S87/143246	850	1100	21	18	6	1	4	5	3	2	2	1	1						Extensive dominant, subalpine
S78/274337	610	1050	30	2	3	5	5	5	3	1	1	2	-	1	-	1			Extensive dominant, montane
*S87/140252	450	1700	2	1	-	1	-	4	-	5	1	2	-	2	3	-	2		Lower limit of montane extensive co-dominant
S77/188315	320	650	7	-	-	1	-	-	-	2									Lower limit of montane extensive co-dominant
S77/149355	530	nm	14	4	3	2	2	1	1	3	2	1	1						Extensive co-dominant, coastal hill
S87/982298	300	nm	1	2	2	1	2	4	1	2	-	-	1						Extensive co-dominant, coastal hill
S77/047330	230	nm	6	1	4	5	3	2	4	1									Extensive co-dominant, coastal slope
*S77/190420	130	900	30	13	10	7	6	3	2	1	-	1	1						Extensive co-dominant, coastal slope
S77/121399	70	650	18	10	9	8	5	6	1	-	-	2	1	-	-	1	-	1	Extensive co-dominant, coastal slope
S77/157423	40	nm	>36	13	5	4	3	2	2	-	1								Extensive co-dominant, coastal terrace
S77/195413	400	300	18	xx		x													Heath forest, with stunted beech to 360 years old
S78/273301	970	150	8	14	1														Beech invading scrub at timberline
S78/352397	840	1500	27	16	9	12	10	12	9	4	3	-	1	1					Old sporadic stand on spur, most margins static
*S87/129290	800	170	48	6	1	2	1	-	1	1	-	1							Sporadic on hill crest, margins advancing
S78/560344	560	260	>18	>6	>15	4	3	3	2	1	-	-	-	-	-	1			Sporadic above riverbank
S78/312431	5	600	30	10	9	5	-	-	-	1	1	1							Sporadic in podocarp forest on wet terrace
*S77/178387	15	1900	-	1	-	-	-	2	-	2	1	-	4	2	-	2	1		Mature sporadic on recent terrace
S78/272448	5	150	12	11	10														Sporadic in podocarp forest on old dune

* Stands illustrated in Figure 4.

nm Area not measured.

> These diameter classes were counted only on a portion of the sample area.

x Trees outside plot.

APPENDIX 2
ESTABLISHMENT DISTANCES OF SILVER BEECH INTO
CLOSED VEGETATION

Altitude (m)	A (cm)	B (cm)	C(m)	D
*980	120	s	13	m
*880	145	s	15	s
820	150	3	2	s
730	130	35	11	s
*720	100d	s	19	s
710	145	19	13	s
610	100	s	14	s
610	175	s	20	s
570	160	15	14	s
560	132	36	25	r
*550	117d	s	61	s
530	140d	s	9	s
320	110	s	14	l
260	130	s	20	l
200	110	25	35	l
20	100	s	18	m

-
- A Diameter of largest tree near margin of stand (d = dead).
- B Diameter of beech plant furthest out from A (s = seedling < 1 m tall).
- C Distance between A and B.
- D Type of margin:
 m = margin of extensive silver beech stand
 s = sporadic stand on crest of hill, ridge or spur
 r = riparian stand
 l = widely spaced beech near lower limit of montane extensive co-dominant stands
 * = margins illustrated in Figure 5.
-