

from seed, but persistence in a given habitat depends on the ability of seedlings to establish. Successful germination depends on conditions of light, temperature and humidity; the existence, cause and duration of dormancy, and the type of seed bed. Seeds may germinate at any time of the year, total germination may occur in a few days or over a period of weeks, or intermittent germination occur whenever conditions are favourable.

Similar factors affect seedling establishment and the effect of competition from the existing vegetation must also be considered. Simple measurements can be made on the rate of growth in height, or the amount of spread of mat plants, or the rate of spread of annuals in each habitat. Differences in growth rate may be a direct response to the environment or may be genetically determined so that the differences are still evident when seedlings from different habitats are grown together in a garden.

Most New Zealand species are evergreens, but do they have a definite growing season, entering a period of physiological dormancy with cessation of active growth in height and production of leaves. The time of cessation of active growth in some species can be

critical for survival in areas subject to heavy frosts. There may be marked differences in time of flowering and fruiting with changes in altitude and latitude.

The effects of grazing and browsing animals; trampling and burning; plant and animal parasites and competition from other plants in the community should be noted.

REFERENCES

- ALLEN, K. R., 1954: *Proc. N.Z. Ecol. Soc.* 2: 1-7.
CLAPHAM, A. R., 1950: *J. Ecol.* 44: 1-11.

DISCUSSION

MISS R. MASON commented on the scarcity of botanists and said that in New Zealand they could not travel sufficiently to collect the necessary data.

DR. CROKER said there was a definite need for these data, and the Society might consider starting a scheme for compiling information on seed production and germination.

MISS L. B. MOORE said that this type of work was already being done, and 10-20 people had projects of this kind in hand, e.g., Miss Mason had information re water plants.

DR. CROKER said she realised information of this kind must exist in notebooks etc. but it should be published.

An Attempt to Measure Local Variations in Climate with Improvised Apparatus

G. T. S. Baylis

This paper is based on work carried out by two Otago University students Mr. P. Wardle and Mr. A. F. Mark, and a more detailed account of it is in course of publication.*

Over fifty improvised gauges read at monthly intervals were used to discover the rainfall pattern on the hill country near Dunedin. Funnels tall enough to hold 8 inches of snow were constructed from galvanised down-piping, and one-gallon paint tins with their lids sealed on were used as reservoirs. Freezing and undue heating of

Table 1. Annual rainfall in inches from gauges sited in pairs.

Improvised gauges	a	b	Diff.
Various localities	54.13	54.12	0.01
in the field	43.17	41.87	1.30
	32.50	32.49	0.01
	29.08	29.73	0.65
	Official Gauge	Improvised Gauge	
Musselburgh	31.62	29.40*	
Lake Mahinerangi	31.18	31.54	

*Reservoir unprotected.

the water collected were avoided by setting the tin in the ground and building a stone cairn about the base of the funnel. The reliability of the results can be assessed from Table 1.

*WARDLE, P. and MARK, A. F., 1956. Vegetation and Climate in the Dunedin District, *Trans. Roy. Soc. N.Z.*, 84: 33-44.

Ten separate tests were made in which a pair or small group of gauges were sited on different aspects of a hill, spur or gully. In seven localities aspect differences in annual rainfall did not exceed 10% but in the remaining three the differences were 15%, 21% and 46% respectively for stations not more than 400 yards apart.

Evaporimeters made from the porous candles used in water filters performed very consistently and were readily calibrated against one another. Quartz-size milk bottles made satisfactory reservoirs. A droplet of mercury held between two pads of cotton-wool in the supply-tube served as a non-return valve preventing recharging of the reservoir by rain and a small tube with a narrow opening admitted air to the reservoir as the water was withdrawn. The evaporimeters were operated only in open country during the summer months.

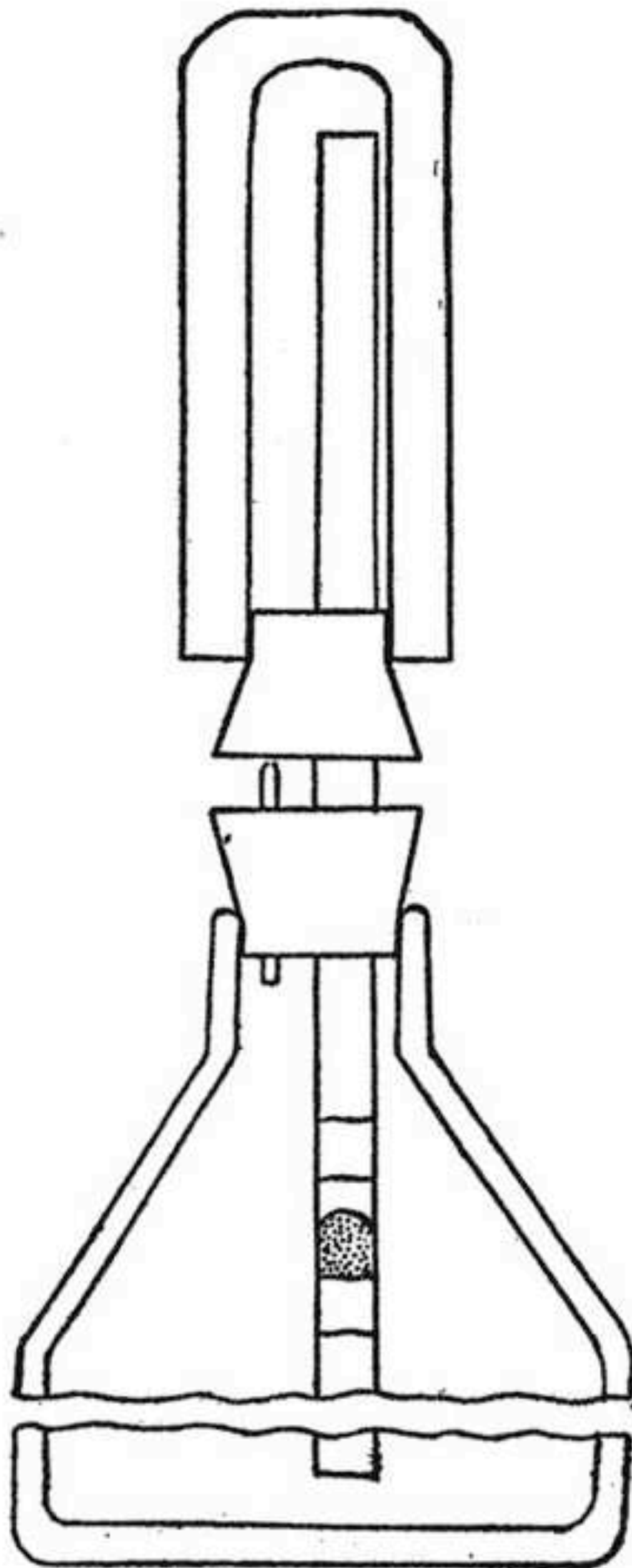

By means of these improvised instruments a general tendency for rainfall to rise and for evaporation to fall with altitude was established over the whole area. The timberline which cuts across the seaward faces of the hills at an altitude of about 1700 ft cannot therefore be regarded as determined in position by any aridity gradient in the upland climate. A correlation was however established between climatic factors and the distribution of montane conifers.

Table 2. Distribution of montane conifers

	Mt. Cargill	Swampy Hill (seaward face)	Mangatua (seaward face)
Rainfall (annual)	54 ins.	53 ins.	41 ins.
Evaporation (summer)	3.1 litres	3.9 litres	4.6 litres
Sea fogs (75 days)	20	20	5
Mt. totara	Living	Living	Living
Kaikawaka	Living	Living	No trace
Pink-pine	Living	Logs only	Logs only

Minimum thermometers simply mounted on iron standards were used to study the temperature inversions during frosty weather. In snow-tussock country as much as 18° F. of ground frost was recorded in a valley bottom while there was only 5° F. of ground frost on the adjacent hillside. In silver-beech country not more than 4° F. of frost was recorded under the forest canopy and not more than 10° F. of frost in clearings. These results indicate how extensively temperature microclimates for seedlings may be modified by deforestation.

DISCUSSION

P. C. BULL referred to the series of climatic records organised on a nation-wide scale by Dr. Mitchell, and asked for details of this work.

N. G. ROBERTSON said that Dr. Bayliss's studies had been in local climate; whereas Dr. Mitchell had attempted to measure the climate within a few yards of his station, a few feet above and below the ground, just in one spot, but these findings could not be considered representative of an area.

R. J. SCARLETT said that in Marlborough on some farmlands, podocarps were turned up a few inches below the surface, although there was no visible sign of a forest.